



## UNI-FLO QP KNIFE GATE VALVE



### HEAVY DUTY BI-DIRECTIONAL KNIFE GATE VALVE WITH INTEGRAL REPLACEABLE POLYURETHANE CARTRIDGE

**Size range:** DN50 - DN600  
**Pressure rating:** DN50 - DN200 16bar  
DN250 - DN400 10bar  
DN450 - DN600 8bar

**Flange connection:** Wafer / semi lugged  
**Body material:** SG Iron BS 420/12  
**Gate material:** 304 (316 & 2205 available on request)

**Body seal:** Polyurethane  
**Yoke material:** FBE coated mild steel (304 & 316 available on request)

**Flanges:** DIN PN10 (other drillings available on request)

### FEATURES

- Integral replaceable polyurethane cartridge that is mechanically retained within a two-piece body
- Bi-directional sealing
- No groove or cavity in the bore of the valve where slurry can collect
- Full bore unrestricted flow
- Precision machining of the stuffing box cavity that reduces the force required to seal the valve which reduces the opening and closing torques
- PTFE scrapers across the width of the blade
- 16bar pressure rating for valves from DN50 to DN200, 10bar for valves from DN250 to DN400 and 8bar for valves from DN450 to DN600
- Self-cleaning flush-out corners that prevents deposit build up in the sealing area
- The spindle is protected against slurry splatter, utilising a spindle cover above the handwheel and bellows below

### SPECIFICATION

The valve will consist of a semi-lugged wafer type, two-piece body. The valve must seal at maximum operating pressure in the direction of flow and the reverse direction. The body seal will consist of a replaceable polyurethane cartridge that is mechanically retained within a two-piece body. The valve must seal to atmosphere in the open position utilising an adjustable stuffing box. The valve design must allow for full bore unrestricted flow. The seat area must contain flush-out corners with no cavities where sediment can collect. The valve must be fitted with PTFE scrapers covering the width of the gate.



# UNI-FLO QP KNIFE GATE VALVE

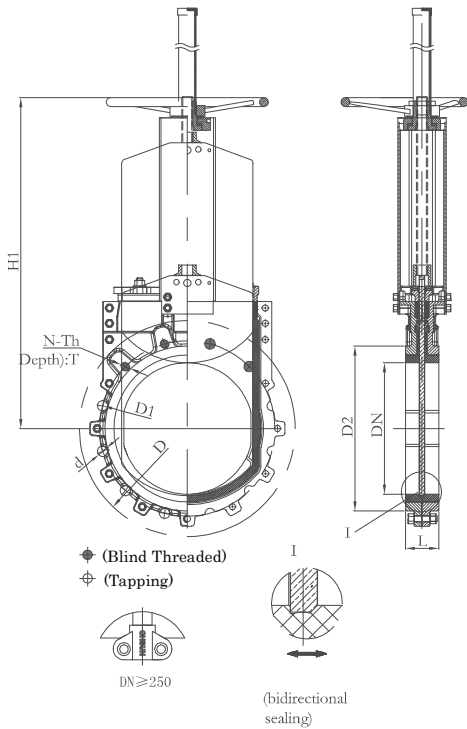

## DIMENSIONS

DN	L	D	D1	D2	D0	N-Th	d	H1
50	48	165	125	99	180	4-M16	Ø18	265
80	51	200	160	132	200	8-M16	Ø18	330
100	51	220	180	156	240	8-M16	Ø18	360
150	57	285	240	211	280	8-M20	Ø23	450
200	70	340	295	266	300	8-M20	Ø23	530
250	70	395	350	319	320	12-M20	Ø23	595
300	76	445	400	370	350	12-M20	Ø23	660
350	76	505	460	429	400	16-M20	Ø23	760
400	89	565	515	480	450	16-M24	Ø27	850
450	89	615	565	530	500	20-M24	Ø27	940
500	114	670	620	582	500	20-M24	Ø27	1050
550	114	725	680	638	-	20-M27	Ø30	Gear
600	114	780	725	682	-	20-M27	Ø30	Gear

## PARTS LIST

	DESCRIPTION	MATERIAL
1	Hand wheel	Ductile Iron
2	Bearing	GCr15
3	Handle Bracket	Ductile Iron
4	Yoke	FBE coated mild steel
5	Stem	SS420
6	Bolt & Nut	Fe+Zn
7	Packing	PTFE+EPDM
8	Gate	SS304
9	Nut	Fe+Zn
10	Body	Ductile iron
11	Seal	Polyurethane
12	Body Seal	EPDM
13	Bolt	Fe+Zn
14	Scraper	PTFE
15	Packing Gland	WCB
16	Spindle nut	Brass

