

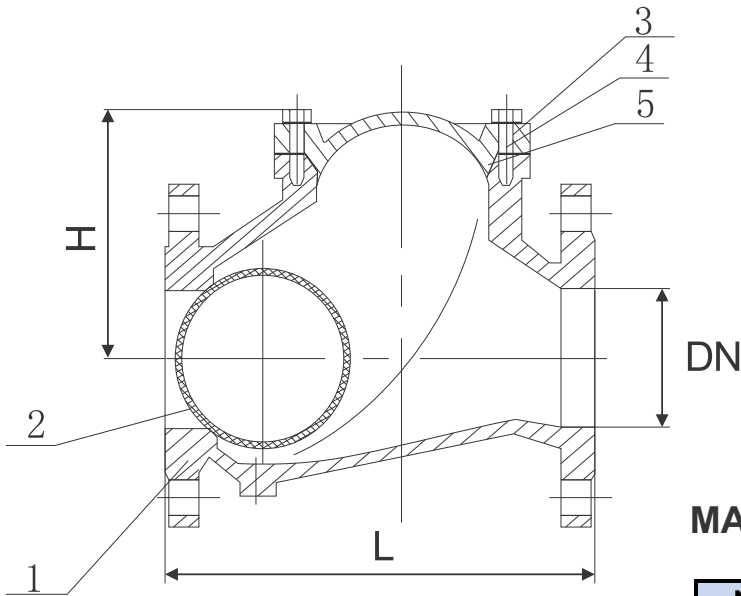

UNI-FLO BALL CHECK VALVE FIG BCV



MATERIALS LIST

NO.	PART	MATERIAL
1	Body	GG25/GGG40
2	Ball	Carbon Steel Rubber encapsulated
3	Cover	GG25/GGG40
4	Nut	Carbon Steel Zinc plated
5	O-Ring	NBR
6	O-Ring	NBR

DESCRIPTION

1. Silent closing, no water hammer
2. Good sealing
3. Full bore flow, large flow
4. Small resistance
5. Loss or water head is 50% lower than swing check valves
6. Installation: horizontal or vertical

Pressure Rating	PN16
Sealing Test Pressure	1.76MPa
Strength Test Pressure	2.4MPa
Suitable temperature	-10°C - + 80°C
Suitable Medium	Water, Sewage Heavy
	Thick and Viscous Liquid

PRESSURE DROP CURVE

FLANGED

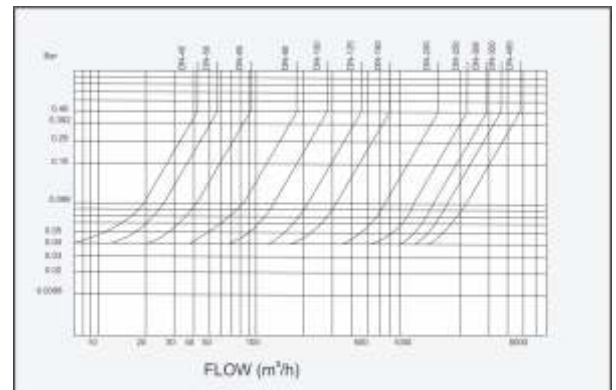

DIMENSIONS

DN		50	65	80	100	125	150	200	250	300
L (mm)	PN10/16	200	240	260	300	350	400	500	600	700
	CL125	203	216	241	292	330	356	495	622	698
H (mm)		126	145	173	186		287.5	320	443.7	529.4