

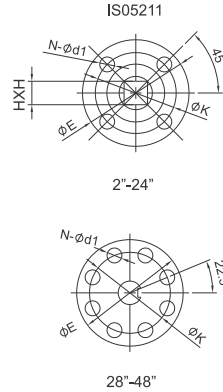

**SANS PAR**

**CAPE TOWN**  
Tel: 021-5110283 - Email: info@sanspar.co.za  
**JOHANNESBURG**  
Tel: 011-3976889 - Email: jhb@sanspar.co.za  
**DURBAN**  
Tel: 031-7002485 - Email: kzn@sanspar.co.za

# UNI-FLO U-SECTION FLANGED WAFER BUTTERFLY VALVE, PN16/CL16/CL125/150

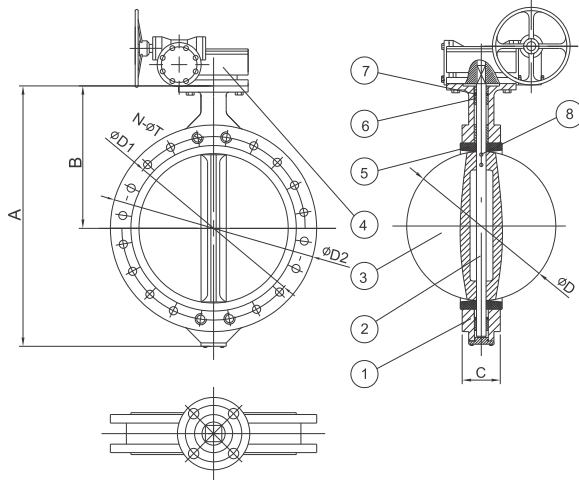

## MATERIALS LIST

NO.	PART	MATERIAL
1	Body	GGG40
2	Stem	416SS
3	Disc	GGG40/316/304/AL.Bronze
4	Body seat	EPDM
5	Bushing	Lubricant Bronze
6	O-ring	EPDM
7	Indicator	Carbon Steel
8	Lever	Cast Iron
9	Half-washer	Steel
10	Washer	Steel
11	Circlip	Steel

## DESCRIPTION

1. Design according to: BS5155
2. Inspection and test DIN3230 part 3
3. Face to face: DIN3202 K1  
(EN558-1 Series 20)

## DIMENSIONS

DN	A	B	C	D	D1	D2	E	K
2"	220	140	42	52.7	125	165	90	70
2.5"	242	152	44.7	64.4	145	185	90	70
3"	246	159	45.2	78.8	160	200	90	70
4"	284	178	52.1	104	180	220	90	70
5"	314	191	54.4	123.3	210	250	90	70
6"	324	204	55.8	155.6	240	285	90	70
8"	390	238	60.6	202.5	295	340	125	102
10"	473	270	65.6	250.5	355	405	125	102
12"	557	315	76.9	301.5	410	460	140	102
14"	635	368	76.5	333.3	470	520	140	102
16"	709	400	86.5	389.6	525	580	197	140
18"	750	422	103.5	440.5	585	640	197	140
20"	841	480	129.5	491.6	650	715	197	140
24"	1021	562	152	592.5	770	840	276	165
28"	1144	624	163	695	840	895	300	254
30"	1199	660	167	745	950	984	300	254
32"	1263	672	188	794.5	950	1025	300	254
36"	1376	720	203	846.7	1050	1115	300	254
40"	1521	800	216	965	1170	1230	300	254
48"	1805	864	276	1160.6	1390	1511	350	295