

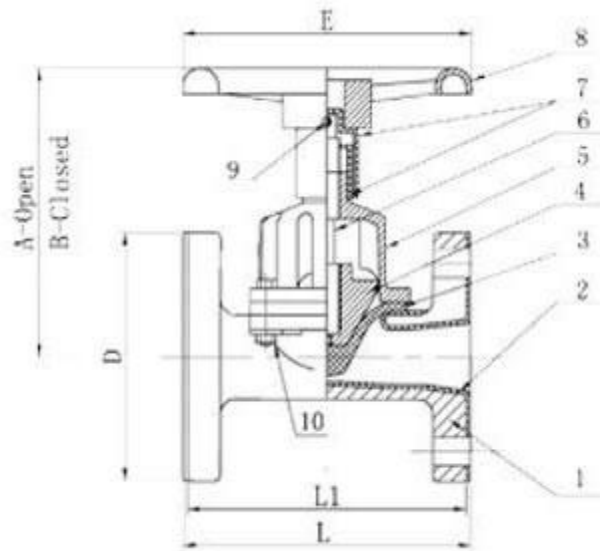

UNI-FLO STRAIGHT THROUGH DIAPHRAGM VALVE

Feature

1. Design and manufacture conform to BS5156.
2. Flange dimensions confirm to BS4504 PN10
3. Working pressure:
DN50-DN100 1.0Mpa
DN125-150 0.6Mpa
DN200 0.35Mpa



MATERIALS LIST

NO.	PART	MATERIAL	QTY
1	BODY	GG25	1
2	BODY LINED	NATURAL RUBBER	1
3	DIAPHRAGM	NATURAL RUBBER	1
4	VALVE CLACK	GG25	1
5	BONNET	GG25	1
6	STEM	STAINLESS STEEL	1
7	BUSH	PLASTIC	2
8	HANDWHEEL	GGG40	1
9	PIN	CARBON STEEL	1
10	BOLT	STAINLESS STEEL	1

DIMENSIONS(mm)

DN	L	L1	A	B	D	E
50	194	190	185	165	165	160
65	222	216	224	200	185	200
80	258	254	273	240	198	250
100	309	305	321	285	220	315
125	362	356	347	305	250	315
150	412	406	447	385	283	400
200	527	521	-	415	335	500