

DIN CAST IRON STRAINER

1. Face to Face dimensions according to DIN3202, F1
2. Flange dimensions according to DIN2501 PN 10/PN16
3. Nominal Pressure PN10/PN16
4. The mesh of wire screen or the hole dimensions of the perforated screen can be as per the customer's requirements.



FIG: 508

MATERIAL LIST

No.	Part	Material	Standard
1	Body	Cast Iron or Ductile Iron	GG25 or GGG40
2	Plug	Cast Iron or Ductile Iron or Steel	GG25 or GGG40
3	Cover	Cast Iron or Ductile Iron	GG25 or GGG40
4	Screen	Stainless Steel	304SS
5	Gasket	Graphite or Rubber	

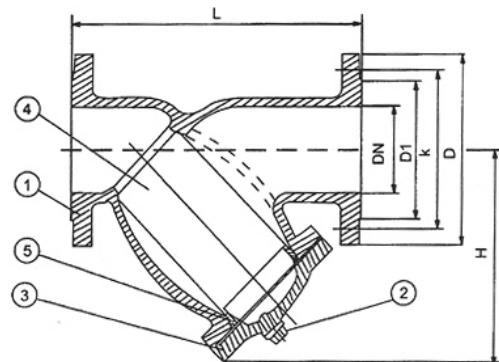

DIMENSIONS (mm)

DN	40	50	65	80	100	125	150	200	250	300	350	400
L	200	230	290	310	350	400	480	600	600	650	980	1100
≈H	105	170	205	210	235	270	310	390	430	500	670	780
D	150	165	185	200	220	250	285	340	405	460	520	580
K	110	125	145	160	180	210	240	295	355	410	470	525
D1	88	102	122	138	158	188	212	268	320	378	438	490

*Flange dimensions can be as per BS10 Table D/E, JIS10K, etc