

CAST IRON FIRE HYDRANT VALVE, Epoxy Powder Coated

HYDRAULIC TEST PRESSURE

Body - 2000 kpa
Seat - 2000 kpa

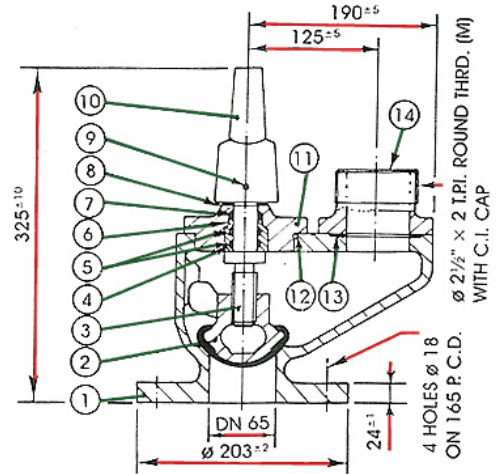

SR. No.	DESCRIPTION	MATERIAL
1	Body	C.I., BS: 1452 GR. 14
2	Valve Plug	C.I., Nitrile Rubber Coated
3	Spindle	S.S. AISI -410
4	Bush	Nylon / Nitrile Rubber
5	O-ring (Spindle)	Nitrile Rubber
6	Profile Ring	Nitrile Rubber
7	Scraper Ring	Nitrile Rubber
8	Friction Ring	Nylon / Nitrile Rubber
9	Roll Pin	Spring Steel
10	Top Cap	Cast Iron
11	Gland Housing	Cast Iron
12	Gasket	Rubber O-ring
13	Gasket	Rubber O-ring
14	Screwed Outlet	Gun Metal BS: 1400 LG 2